

# **COMPRESSOR REFRIGERATOR**

**KL50**

**USER MANUAL**

Instrukcja obsługi  
dostępna również na:  
User manual  
also available at:  
Bedienungsanleitung  
erhältlich auch bei:



## 1. Explanation of symbols.



### **DANGER!**

Safety note: Non-observance can result in death or serious injury.



### **CAREFULLY!**

Safety note: Failure to comply can result in injury.



### **ATTENTION!**

Non-observance can lead to material damage or interference with the product.



### **TIP**

Supplementary information on product handling.

**Please read this manual carefully before starting the device. Keep these instructions. The manufacturer is not liable for damages resulting from improper use or incorrect operation.**

Warnings and Important Safety Instructions in this manual do not cover all possible conditions and situations that may occur. It is your responsibility to use common sense, caution, and care when installing, maintaining, and operating your appliance.

## 2. Safety information



- The device and / or its power cord may not be used if they show any signs of damage.
- If the device requires repair, contact the manufacturer's service. Contact details can be found at [www.arkas.pl](http://www.arkas.pl).
- Repairs may only be carried out by qualified persons. Self-repair can cause serious health or life hazards.
- For safety reasons, replacement of the LED lighting (selected models) should be performed by the manufacturer or an authorized service center.
- The device should be connected to a power source that complies with the data included in the technical specification, only with the supplied power cords. 100-240V power supply requires cable connection via the AC / DC adapter. Do not place extension cords with multiple sockets or portable power adapters near the ventilation openings of the machine.
- The device must be disconnected from the mains after each use and before cleaning / maintenance.
- This appliance can be used by children aged from 8 years and above and persons with reduced physical, sensory or mental capabilities or lack of experience and knowledge if they have been given supervision or instruction concerning use of the appliance in a safe way and understand the hazards involved. Children shall not play with the appliance. Cleaning and user maintenance shall not be made by children without supervision.
- Children aged from 3 to 8 years are allowed to load and unload cooling device.
- Do not lean on or hang on the open door of the appliance. It may damage the device and / or lead to personal injury.
- Do not move the device over surfaces susceptible to damage and scratches.
- Do not store caustic substances, containing solvents, which are known to be explosive or compressed flammable gases in the device.
- Do not use electrical appliances inside the food storage compartments of the appliance, unless they are of the type recommended by the manufacturer.
- Do not use mechanical devices or other means to accelerate the defrosting process, other than those recommended by the manufacturer.
- This appliance is intended to be used in household and similar applications such as
  - Staff kitchen areas in shops, offices and other working environments
  - Farm houses and by clients in hotels, motels and other residential type environments
  - Bed and breakfast type environments
  - Catering and similar non-retail applications
- This refrigeration appliance is not intended to be used as a built-in appliance.
- This refrigeration appliance is not suitable for the freezing of foodstuffs.
- The two-star freezer compartments are used to store previously frozen food, store or freeze ice cream, and freeze ice cubes.
- One-star, two-star and three-star compartments are not intended for freezing fresh food.
- The refrigeration appliance is intended for use in an ambient temperature ranging from 10 ° C to 32 ° C, or 16 ° C to 32 ° C, or 16 ° C to 38 ° C, or 16 ° C to 43 ° C. Detailed information can be found in the "technical data" section of this manual.
- Protect the device against adverse weather conditions such as rain. The device is not waterproof.
- Do not use or store the device near fire or other heat sources.
- During operation, the device should be located in a well-ventilated room. Ensure adequate space between the device and other equipment (≥200mm on the back of the device, ≥100mm on the sides of the device).
- The appliance cooling system contains flammable refrigerant R1234YF.  
The device that is not fit for further operation should be delivered to a specialized recycling facility.



**Caution:**  
**Risk of fire / Flammable materials**

- It is forbidden to interfere with the refrigeration system and its circuits in order to modify or damage it. If the refrigerant system was accidentally damaged or a refrigerant leak is found, immediately remove all sources of ignition found in close proximity to the device. If the device is in a room, ventilate it immediately.

## 2. Safety information cont.

- Before disposing of the old appliance, remove the door, but leave the inner baskets and partition wall (selected models) so that children cannot get inside.
- The manufacturer's warranty period - 24 months from the date of purchase.
- The minimum period for which spare parts necessary to repair are available is 7 or 10 years, depending on the type and purpose of the spare part, and is in line with Commission Regulation (EU) 2019/2019. The list of spare parts and the ordering procedure are available on the websites of the manufacturer, importer or authorized representative. More information about the product can be found in the EU Product Database EPREL at <https://eprel.ec.europa.eu>. Information can be obtained by scanning the QR code on the energy label or by entering the product model from the energy label in the EPREL search engine <https://eprel.ec.europa.eu>.

## 3. Description of operation and basic function



- The refrigerator is intended for storing food.
- Thanks to high-class insulation and an efficient compressor, the cooling process is extremely fast.
- The device has two compartments (fresh food compartment and frozen compartment) with separate temperature control - Dual-Zone.
- The fridge can be powered from DC 12/24V or AC 100-240V or battery (external battery - not included).
- The device has multi-level protection of the vehicle battery against discharge and overvoltage protection to protect against sudden voltage surges in the electrical network.
- The control panel with a clear LCD screen enables intuitive control of the device.
- The fridge is equipped with a Bluetooth 5.0 transmitter. This allows you to control it using an application designed for mobile devices (Android / iOS).
- A drawer and shelves for easy content management.
- The portable fridge is suitable for camping use.

## 4. Contents of the package





- Compressor refrigerator
- Drawer
- Wire shelf
- 2x door shelf
- Ice cube tray
- 12/24V power cord (length: 3.5m/11,4ft)
- AC/DC adapter with 100-240V power cord (EU/UK)
- User manual

## 5. Directions for use



- Before first use, remove the device from the packaging, clean the inside of the device with a damp cloth and wait 6 hours.
- **The device should be in a standing position during operation. The maximum angle of inclination of the device relative to the ground should not be more than 5°.**
- If the device is used with the ignition off of a motor vehicle (when using a 12 / 24V power source), it switches itself off when the voltage drops below the set battery protection value. The device will turn on again when the required voltage is obtained by charging the battery. The device must be turned off or disconnected from the power source when charging the battery of the vehicle.
- When using the battery, it is recommended to change the battery protection mode to low .

Battery protection mode	Low (L) 	Medium (M) 	High (H) 
Switch-off voltage with 12V supply	8.5V	10.1V	11.1V
Restart voltage with 12V power supply	10.9V	11.4V	12.4V
Switch-off voltage with 24V supply	21.3V	22.3V	24.3V
Restart voltage with 24V supply	22.7V	23.7V	25.7V

To avoid contamination of food, please respect the following instructions:

- Do not open the appliance door more often than necessary. This may significantly increase the temperature inside the device.
- Foodstuffs should be stored in their original packaging or appropriate containers. Store raw meat and fish in suitable containers in the refrigerator, so that it is not in contact with or drip onto other food.
- Clean regularly surfaces that can come in contact with food.
- Too low or too high temperature may adversely affect the stored food. The temperature inside the refrigerator should be adjusted to the temperature recommended by the food manufacturer.
- If the device is left empty for long periods:
  - Switch off the device.
  - Defrost the device.
  - Clean and dry the device.
  - Leave the door open to prevent mould developing within the appliance.

- An example of the arrangement of food products

Compartment type	Target storage temperature	Adequate food
Fresh food compartment	0°C ≤ +4°C	Fresh pork, beef, fish, chicken, cooked food etc.
Frozen compartment 	≤ -12°C	Seafood (fish, shrimp, mussels), freshwater products and meat products, not suitable for frozen fresh food.

- Once defrosted, the products should not be re-frozen or stored in the frozen compartment.
- Glass containers, bottles, cans and carbonated drinks should not be stored in the frozen compartment.

## 6. Operating

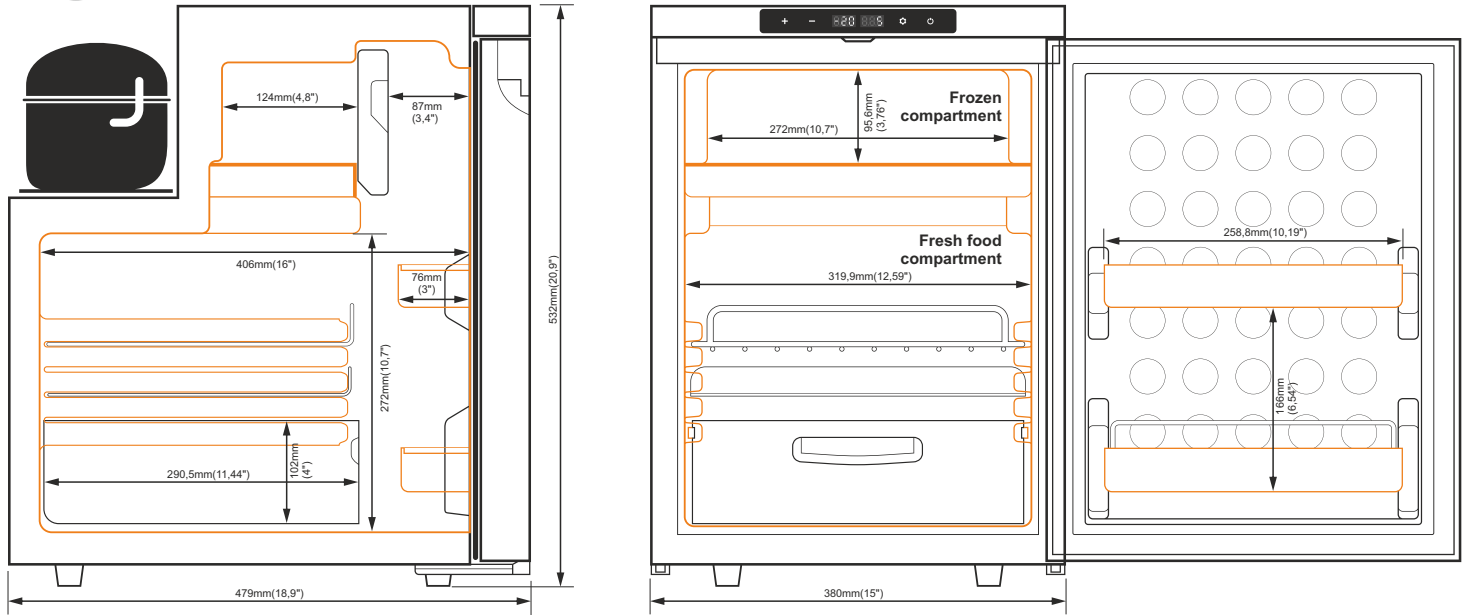

### Operating the device from control panel

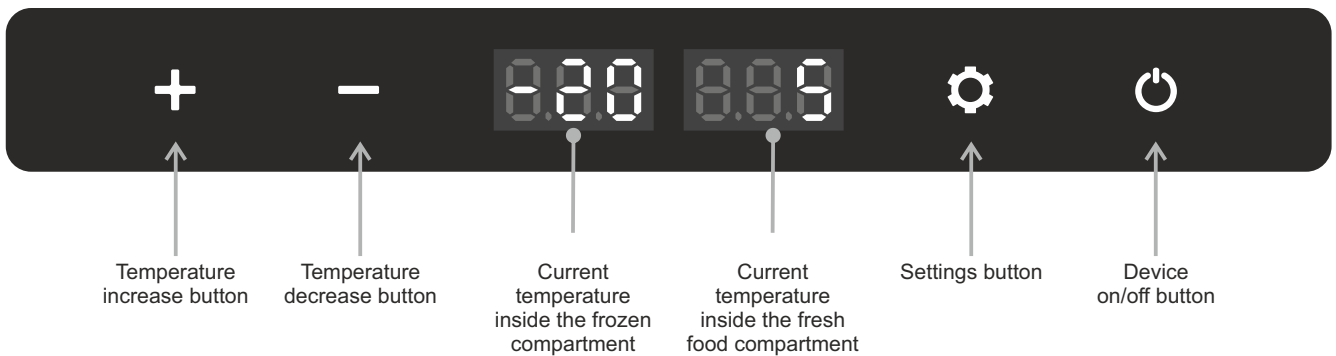

Button	Function
Device on/off button	Pressed once will turn on/off the device
Temperature increase button	Buttons responsible for setting the temperature inside the device. A single press  increases the temperature A single press  lowers temperature
Temperature reduction button	
Settings button	Pressed once will change the active compartment
	Press and hold to change between car battery protection modes (when powered from a 12 / 24V socket in motor vehicles):  (high protection) /  (medium protection)  (low protection).
	When connecting the device to the application via Bluetooth: Pressed once, when the "AP" message appears on the device control panel, will enable connection with the application on the external device.

### Changing the temperature scale on the control panel (°C/°F)

With the device turned off, press and hold the button until the message E1 appears. Then press the button several times until the content of the message changes to E5. Use the button or to switch between the °C and °F temperature scales. Turn off the device using the button to save the setting.

### Operating the device from the application level (Android / iOS)

The application **Yoico** can be downloaded from the GooglePlay store (for Android devices) or AppStore (for iOS devices). For the proper operation of the application, it is required to turn on the Bluetooth function and the location function on the external device.

To connect to the application, launch it on an external device (smartphone / tablet), search for and select the fridge from the list of available devices. The refrigeration appliance control panel will display "AP", which must be confirmed by pressing the button . The device should be ready for receiving commands from the application.



### Changing door opening direction.

To change the door opening direction:

1. Take all the products out of the appliance
2. Gently place the device in a horizontal position - with the door facing up

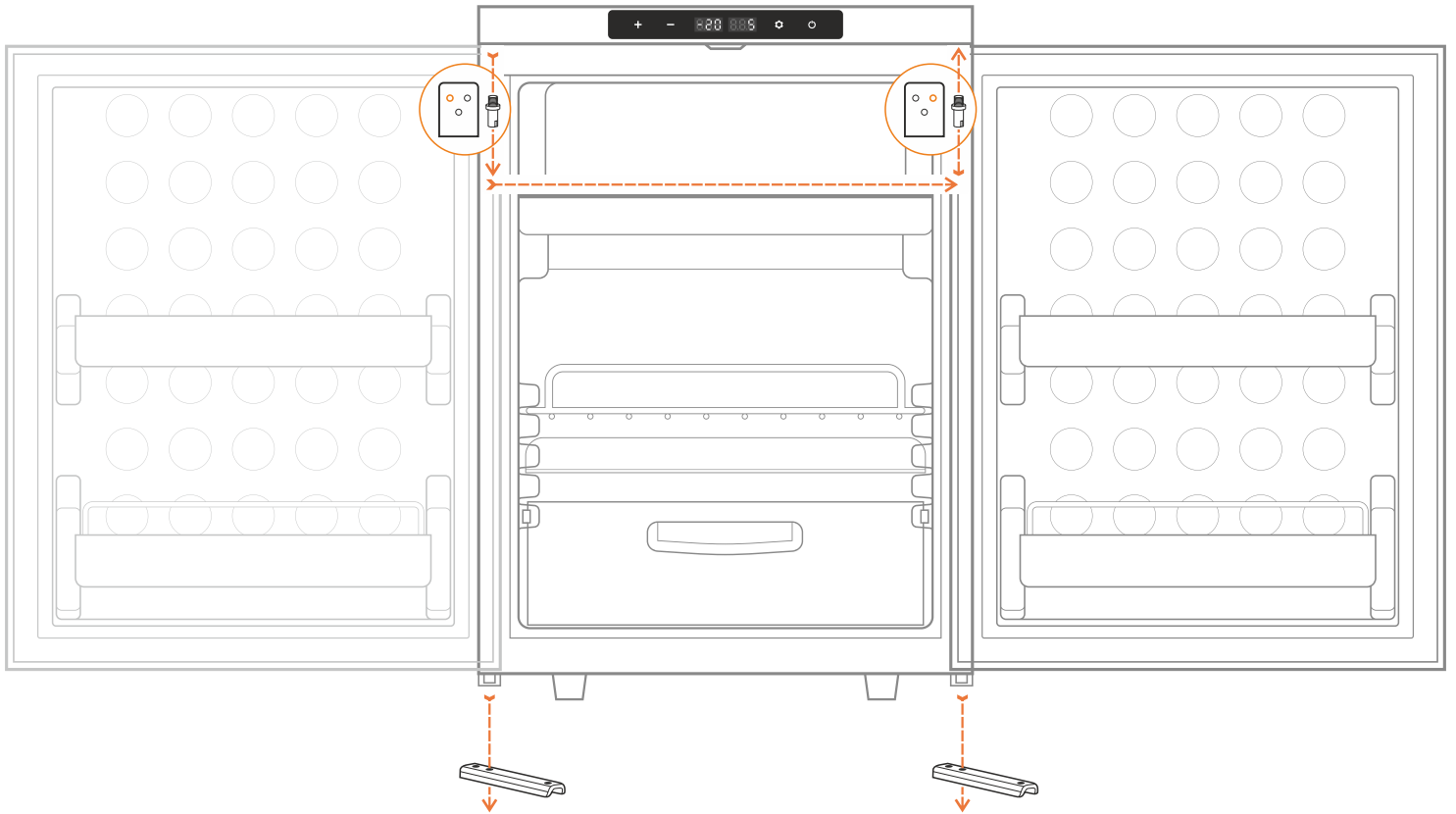

3. Unscrew the lower door hinge and the base on the opposite side. Then pull the appliance door downwards.
  4. Put the mounting plugs in the remaining holes in the upper edge of the door.
  5. Slide the door into the top hinge
  6. Screw on the bottom door hinge and the base
  7. Place the device in an upright position
  8. Check that the appliance door closes smoothly. If you encounter any resistance, check if the bottom Hinge is not bent or over tightened.
- Attention! Wait 6 hours before restarting the device.**

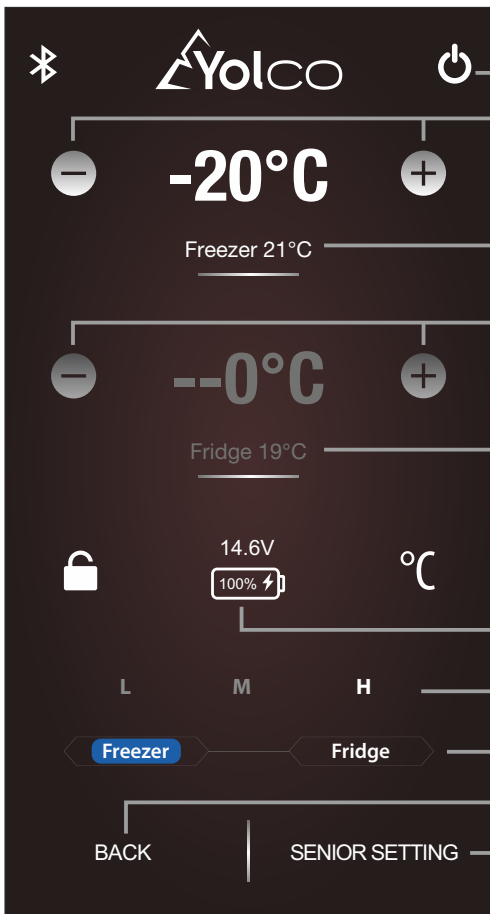

Device on/off button

Buttons for changing the target temperature inside the freezer compartment

The current temperature inside the freezing chamber

Buttons for changing the target temperature inside the fresh food compartment

The current temperature inside the fresh food storage compartment

External battery charge level(not included)

Battery protection mode change buttons (L / M / H)

Compartment selection buttons

Return to the previous screen

Button for changing the advanced settings of the active chamber

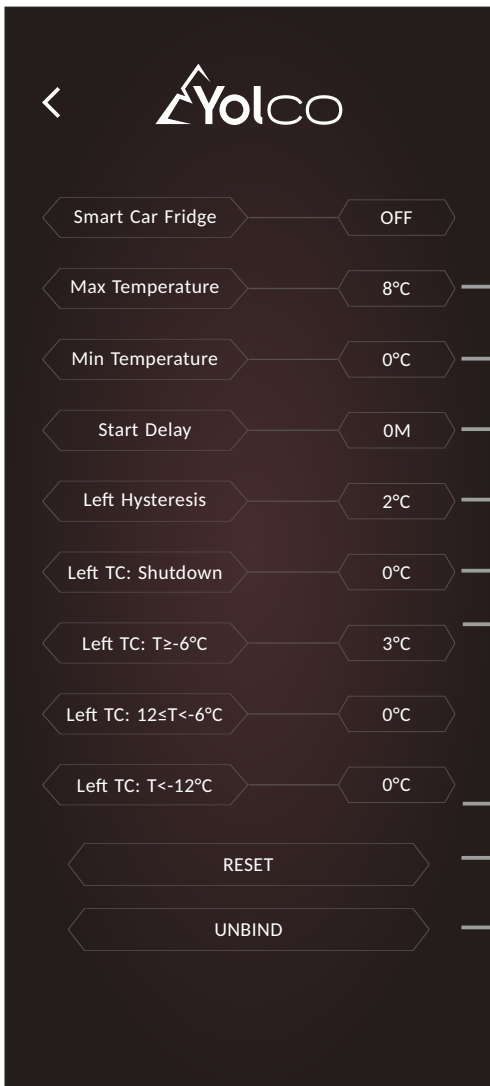

Setting the max temperature

Setting the min temperature

Setting the compressor start delay after starting the device ( in minutes)

Chamber hysteresis setting - the compressor will start after exceeding the sum of the set device temperature and hysteresis temperature (example - cooling temperature set on the device: -20°C, hysteresis temperature: + 2°C, compressor restart temperature: -18°C)

Setting delaying / accelerating the compressor off after reaching the temperature set on the control panel

Settings enabling leveling of differences between the actual temperature of the interior of the device and the temperature set on the control panel (example - chamber cooling temperature set on the device: 0°C, actual temperature inside the chamber: -5°C, the temperature should be set to level the + 5°C differences)

Restoring the default settings of the application

Disconnecting the Bluetooth connection

The description as well as the design may change with future updates to the app.

## 7. Cleaning and maintenance



- Turn off the device and disconnect it from the external power supply before each cleaning.
- The device must not be cleaned under running water.
- Do not use aggressive cleaning agents for cleaning.
- Clean the outside and inside of the device with a damp cloth without the control panel, power section, modular battery socket or ventilation openings. All sections mentioned above clean with dry and soft cloth.
- Manual defrosting  
During long-term operation of the device, a layer of frost may appear inside it. This can reduce its performance. To defrost the device, disconnect it from the power supply, empty the cooling compartment and leave the door open. After frost has condensed, wipe off the remaining water with a soft cloth.

• Replacing the fuse  
**CAUTION! Before replacing the fuse, turn the device off and disconnect it from the power supply.**

1. Remove the fuse cover located in the immediate vicinity of the power socket.
2. Remove the fuse and replace it with a new one with the same technical parameters.
3. Reinstall the fuse cover.

### Fuse specification

Current Rating	15 A
Voltage Drop	102mV
Cold Resistance	4.8 mΩ
I2t	340 A²s

## 8. Troubleshooting the most common faults



Foodstuffs have been frozen:

- Change the cooling temperature to higher, the set temperature is too low.

The device makes a sound of flowing liquid:

- This sound is normal.

Droplets of liquid appear around the fridge door:

- Liquid droplets appear due to the temperature difference between the device and its surroundings, and are normal.





When starting the device, the compressor makes a loud noise:

- It is normal for the compressor to work loudly at start-up

The device does not work:

- Check if the device has been switched on with the button .
- Check that the device is correctly connected to the power source.
- Check whether the power supply is functional.
- Check if the fuse has blown.

The device displays the F1 code:

- Code informing about 12 / 24V supply voltage drop. Change the protection setting to lower from H  (high) to M  (medium) or from M  (medium) to L  (low).

The device displays the F2 code:

- Code informing about fan overload. Switch the device off and on again after 30 minutes.

The device displays the F3 code:

- Code informing about activation of protection against too frequent compressor operation. Switch the device off and on again after 30 minutes.

The device displays the F4 code:

- Code informing about compressor overload. Switch the device off and on again after 30 minutes.

The device displays the F5 code:

- Code informing about compressor module overheating. Switch the device off and on again after 30 minutes.

The device displays the code F6:

- Code informing about the inability to read parameters by the device controller. Restart the device. If the problem persists, please contact your dealer.

The device displays the code F7 or F8:

- Code informing about temperature sensor error. Please contact the seller.

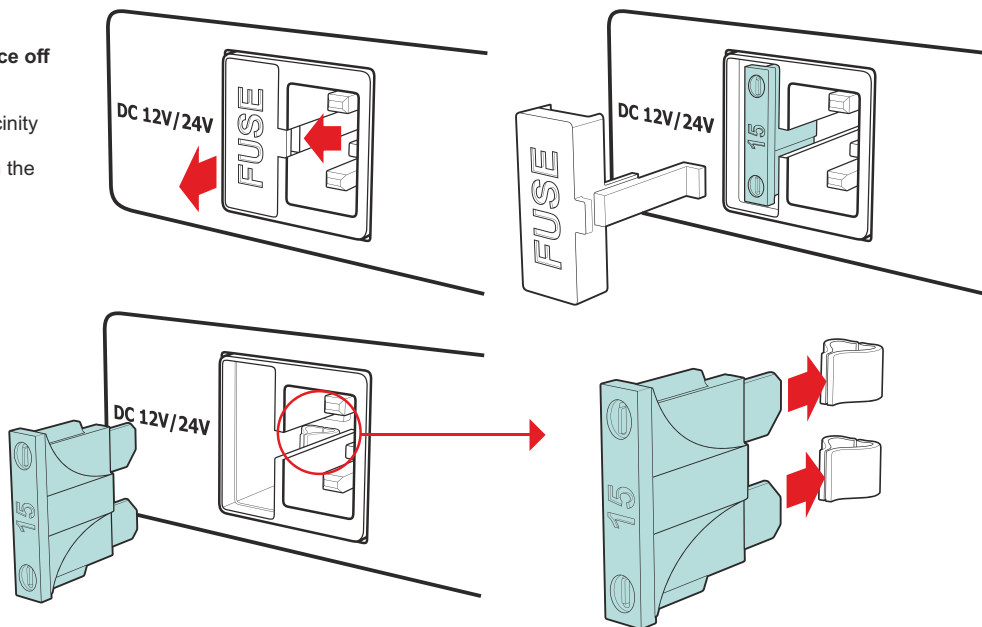

## 9. Technical data



<b>Product model:</b>	<b>KL50</b>
Total capacity	44 L (9,7 gal)
Fresh food compartment net capacity	41 L (9,0 gal)
Frozen compartment net capacity <del>(*)</del>	3 L (0,7 gal)
Input voltage	DC 12/24V AC 100-240V, 50/60Hz
Rated current	DC 12V/5A, 24V/2.5A AC 100-240V, 1.2-0.5A
Number of cooling compartments	2
Fresh food compartment temperature range	from 0°C to +8°C (from 32°F to 46,4°F)
Frozen compartment temperature range <del>(*)</del>	from -20°C to -12°C (from -4°F to 10,4°F)
Power consumption	60W
Climate class	N, T, SN, ST
Ambient temperature	from +10°C to +43°C (from +50°F to +109,4°F)
Emitted noise level	48dB
Refrigerant	R1234YF (26g)
GWP	4
Connectivity	Bluetooth 5.0 (working range up to 10 m/32,8 ft)
Frequency range	2402 MHz – 2480 MHz
Maximum radio frequency power	2 dBm
Dimensions (W x H x D)	380 x 532 x 479 mm (inches: 15,0" x 20,9" x 18,9")
Net weight	14,1 kg (31,1 lb)
Gross weight	18,1 kg (39,9 lb)

### MANUFACTURER'S DECLARATION

Arkas Sp. z o.o. declares that the KL50 Compressor Refrigerator complies with the European Parliament and Council Directives 2009/125 / EC and 2014/53 / EU of April 16, 2014. on the harmonization of the laws of the Member States concerning the making available on the market of radio equipment and repealing Directive 1999/5 / EC. The full text of the EU declaration of conformity is published at [www.arkas.pl](http://www.arkas.pl)

The crossed out wheeled bin symbol means that this product should not be disposed of with other household waste. Waste electrical and electronic equipment should be sent for recycling and recycling with environmental protection regulations in force in a given country regarding waste management. Selective waste collection contributes to reducing their potential negative impact on human health and the resulting environment from the presence in the equipment of dangerous substances, mixtures and components.

67/POW/23

Manufacturer:  
ARKAS Sp. z o.o.  
ul. Kuziennicza 4,  
59-400 Jawor, Poland  
[www.arkas.pl](http://www.arkas.pl)  
[www.yolco.pl](http://www.yolco.pl)



Follow us on



### POWER SUPPLY SPECIFICATION

Manufacturer:	Foshan Great Power Co.,Ltd
Commercial registration number:	91440606663372921C
Adress:	3/F Block, 16th, Street#3, Fengxin Road, Fengxing Industrial Zone, Shunde District, Foshan City, Guangdong Province, Chiny
Model identifier:	GRT90-145600
Input voltage:	100-240V
Input AC frequency:	50/60Hz
Output voltage:	14,5V
Output current:	6,0A
Output power:	87W
Average active efficiency:	90%
Efficiency at low load (10%):	89%
No-load power consumption:	0.19W